

Truck & Bus alignment accessories

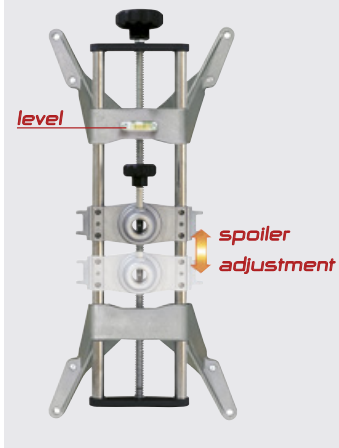

4 point



STDA30E

Coppia di griffe autocentranti a vite a 4 punti in presa, comprensive di unghiette lunghe removibili. Traversa centrale mobile per adattare la posizione del rilevatore al telaio del veicolo.

Pair of self-centering 4 point clamps with long removable claws. Moving centre crosspiece to adapt the position of the sensor to the vehicle body.

Paar selbstzentrierende 4-Punkt-Halter, inklusiver langen entfernbarer Klauen. Die Messkopfhalterung kann senkrecht verschoben und somit dem Chassis angepasst werden.

Paire de griffes autocentreuses à vis à 4 points, avec doigts démontables. La partie centrale mobile permet d'adapter la position du capteur au chassis du véhicule.

Par de garras con autocentrado de 4 puntos. Incluyen uñas largas desmontables. La guja central móvil permite de adaptar la posición del captador al chasis del vehículo.

Standard:



8 x 55 mm (2.2")



Unghia in presa
Rim grabbing claw
Kralle
Doit en prise
Uña en agarre



12"-28"



>700 mm (27,5")

4 point + quick lock



STDA48E

Coppia di griffe autocentranti a vite a 4 punti in appoggio, comprensive di gruppi di bloccaggio rapido e puntali in metallo.

Pair of self-centering 4 point clamps, with quick locking units and metal removable claws.

Paar selbstzentrierende 4-Punkt Schnellspanhalter, inklusiver Radhalter und Metallfinger.

Paire de griffes autocentreuses à vis à 4 points, avec ensemble de blocage rapide avec embouts en metal.

Par de garras con autocentrado de 4 puntos de apoyo. Incluyen grupos de bloqueo y uñas metálicas.

Standard:



8 x 55 mm (2.2")

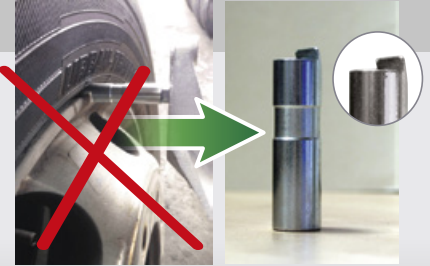

Unghia in appoggio
Rim contact claw
Metallfinger
Doit en appui
Uña en apoyo



12"-28"



>780-1220 mm (30"-48")

3 point - no run out

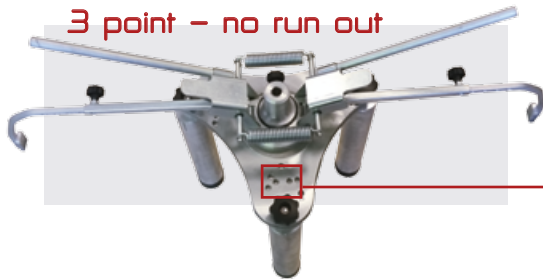

UNIVERSAL



>890-1290 mm (35"-50")



NO RUN OUT

High accuracy

15-20 min faster



STDA92

Coppia di griffe autocarro speciali per evitare la compensazione: agiscono sul centro della ruota che è molto preciso, garantendo ottime misurazioni senza bisogno di sollevare ogni ruota. Questo utilizzo **aumenta la precisione e fa risparmiare 15-20 minuti per veicolo.**

Set of 2 non-runout quick adapters. By referencing the wheel center which is almost perfectly accurate, we can deliver a more accurate measurement without need to raise each wheel position to perform runout compensation. This improves accuracy while saving 15-20 minutes per truck.

Satz zwei kompensationsfreie Schnellspanhalter für NFZ. Diese Halter liegen direkt auf der Radmitte, die sehr genau ist uns erlauben sehr genaue Vermessungen ohne das Rad hochzuheben. Der Einsatz dieser Halter garantieren nicht nur eine **höhere Genauigkeit sondern auch eine Zeitersparnis von 15 bis 20 Minuten pro Fahrzeug.**

*Paire de 2 griffes PL spéciaux pour éviter le dévoilage qui agissent sur le centre de la roue en garantissant une haute précision. On obtient des mesures excellentes sans soulever chaque roue. Ce dispositif **augmente la précision et apporte un gain de temps de 15 à 20 minutes par véhicule.***

Par de garras para camiones, especiales para saltar el alabeo del vehículo. Las garras actúan sobre el centro de la rueda con mucha precisión y garantizan medidas súper fiables. Con este utilizzo **augmentamos la precisión y ahorramos el tiempo de alineado entre 15 y 20 minutos.**

Standard:



6 x 70 mm (2.75")



6 x 345 mm (13.5")

Option:

STDA92A1 (6 x kit)



6 x 200 mm (8")

Turntables

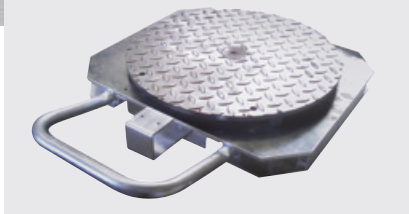

STDA29L - Ø 370 mm (14.56")
Coppia piatti rotanti autocarro. Portata 2x 4500 kg.
Set of 2 commercial turn tables. Capacity 2x4500 kg (2x10000 lbs).
Paar Drehteller für LKW's. Tragfähigkeit 2x4500 kg.
Jeu de 2 plateaux pivotants PL. Capacité 2x4500 kg.
Juego de 2 platos mecanicos para camiones.
Capacidad 2x4500 kg.

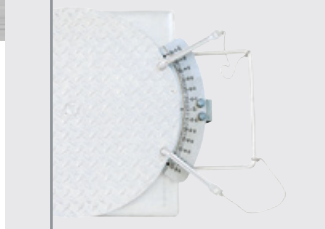

STDA44L (→ STDA29L)
Coppia goniometri.
Graduated scale.
Paar Winkelmesser.
Echelle graduée.
Escala graduada.

STDA30E upgrade

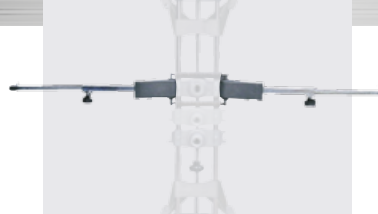

STDA55 (→ STDA30E)
Coppia gruppi di bloccaggio per upgrade
Couple of quick-locking arms for upgrade
Umrüstsatz
Pair de bras de blocage
Para de grupos de bloqueo

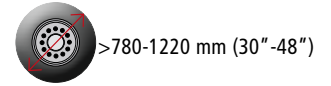

Trailer



STDA49N

Adattatore per allineamento rimorchio
Adapter for trailer alignment
Adapter für LKW-Anhänger Vermessung
Adaptateur pour alignement remorque
Adaptador alineacion semi-remolque

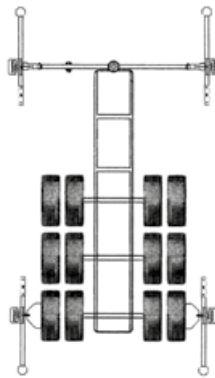
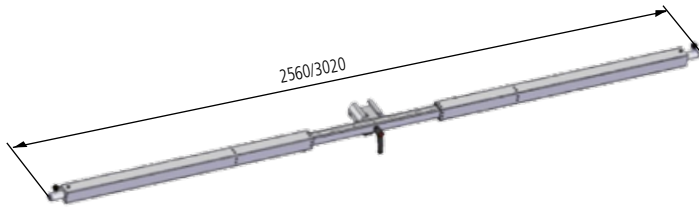

ADAPTER N° 1 (standard)



ADAPTER N° 2 (standard)

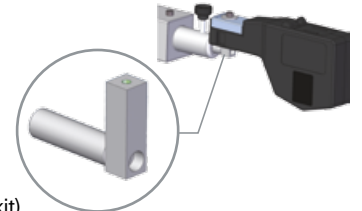

STDA130 (2 x kit)

Supporti per punti focali posteriori per assetto truck 4CCD WS
Rear focal points supports for 4CCD WS truck aligner
2 Fokalfunkte-Halter für 4CCD WS LKW-Achsmessgeräte
2 supports pour émetteurs de géometrie PL 4CCD WS
2 soportes para puntos focales de alineadora camiones 4CCD WS

(Truck) + Car



ACCESSORI PER AUTO / ACCESSORIES FOR CAR / ZUBEHÖR FÜR PKW
ACCESSOIRES VL / ACCESORIOS COCHES

Calibration



STDA14
Sistema di taratura.
Calibration kit.
Kalibriervorrichtung.
Système d'étalonnage.
Kit de calibración.

4 point

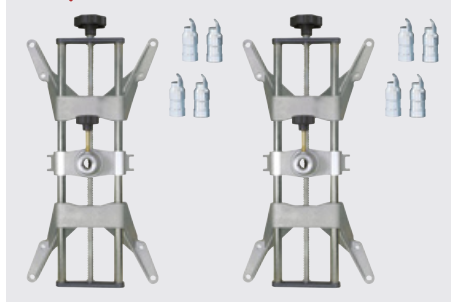

STDA33EU 10"-24"

Turntables

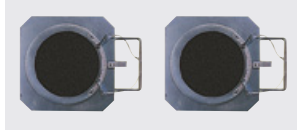

S110A7 - Ø 310 mm (12.2") 2x1000 kg